

SKEW CHISELS

Alan Lacer www.alanlacer.com

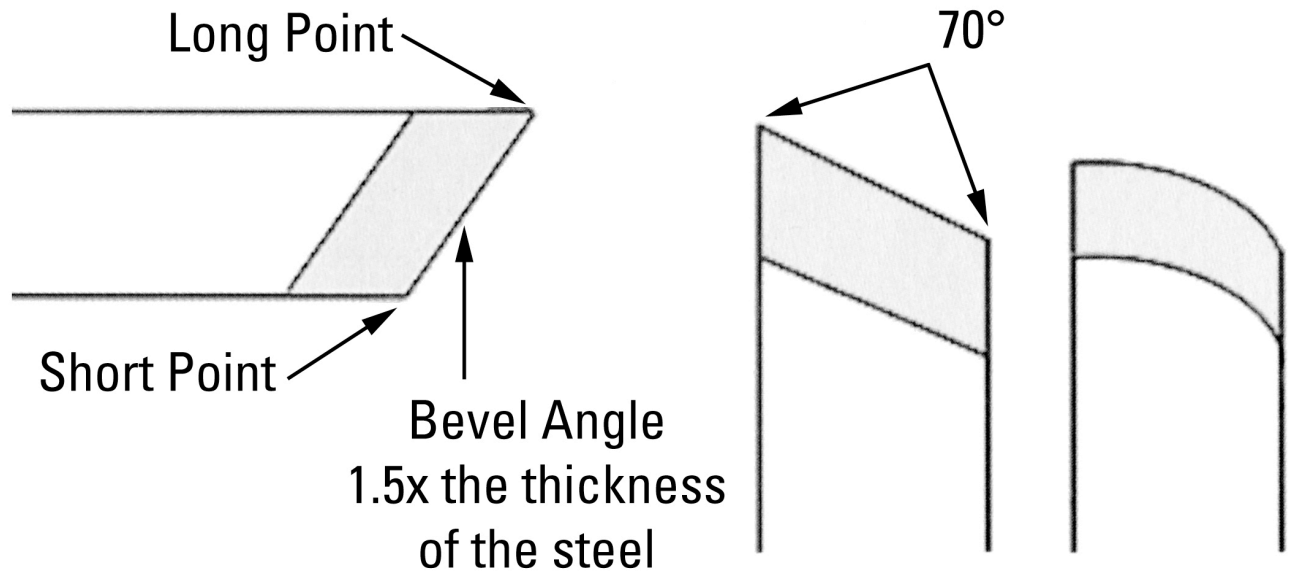

SKEW CHISEL SELECTION: I prefer rectangular sectioned skews, the heavier the better (at least 1/4" thick, better yet, 5/16" or 3/8") with the short point side corners rounded back to the ferrule, the long point side corners chamfered (slight rounding) back to the ferrule. I do not like the oval sectioned skews: they are overly thinned out, rock on the tool rest when grinding, nearly impossible to do the peeling cut (which I use a great deal), and presents a changing angle to the wood as presented in several of the cuts below—such as the rolling cut.

Sizes: I primarily work with two sizes: a smaller one that is 1/2" or 5/8" and a larger one that is 1 1/4" or 1 3/8". These sizes work well on all the cuts below on stock 4" in diameter down to miniature sizes.

Preparation: get it sharp through grinding, refine the edge through hand honing (I prefer a diamond hone) and as an option, power hone using power honing on a MDF wheel charged with buffing compound that cuts high speed steel. Make sure the tool rest is filed flat and clean, wax the top surface of the rest. Drive the work with a cup center rather than a spur—especially if you are in a learning phase.

CUTS:

PLANING: most commonly done with the short point down and leading the cut—but cutting anywhere along the area just above the short point to just above center of tool, handle is positioned at about 45 degrees to the axis of lathe. Problems: skating, dig-in, ribbing, chip-out.

ROUGHING: using the tool in the same position as the planing cut, the skew can be used to round smaller diameters (usually under 2 1/2") and shorter pieces (generally under 18" in length). Is very much a pushing off of the corners to reach the cylinder. In chippy woods like red oak or ash, I either use the planing approach but shorten the length of each cut or use a peeling approach—followed by a planing cut to clean the surface.

PEELING: using the skew like a veneer peeler's action on a log. The cutting edge is held parallel to the lathe's axis, but with the handle low in back to provide a cutting edge that has bevel support—not a scraping action with just a sharp edge. Place the long point against the side of the wood you intend to keep. I normally use only a portion of the tool's edge as too heavy of a cut is hard to make or control. This is a sizing and rough cut—not for finishing. It can be used to take the corners off of a square, cut tenons, or remove large amounts of waste material.

VEE: long point down, cutting with an arcing motion. For the first cut, the point is at a right angle to the axis of the lathe. To deepen or widen the "V" that is created, come from the side of the

original cut, being sure to clear the long cutting edge away from the area just cut. Problems: skating, burning, “stalling out.”

SHOULDER or FACING-OFF: long point is down, long cutting edge is tilted away from the face of the shoulder only a few degrees (2 to 5). Cut is performed high on the work, using an arcing motion and ending above the center axis of the lathe. Problems: skating on entry or at any time on the face of the shoulder, dig-in, “stalling out,” torn grain.

SAUCER: done very much like the shoulder cut, except the action is now concave. Since this is cutting somewhat against the grain, don’t take the cut too deeply into the end-grain. Useful in doing the bottom of projects like a goblet, vase, toothpick holder, lidded box, etc. or for cutting rings free on a shaft.

PARTING: done with the long point down, a series of vee cuts to part a small workpieces/projects off at the headstock side. Tends to avoid many of the problems of parting tools: cleaner cut on the end-grain and seldom snaps the piece off near the conclusion to create a small hole in the end of the project.

PUMMEL: the process of turning square elements that transition into round. I prefer to cut these with the long point down—especially square shouldered pummels. Layout the placement with a single 90-degree line (using a square or protractor). Cut to the waste side with a Vee cut—then turn away material on the waste side until you reach a cylinder (using either a peeling or planning cut). Make the cut to the line using the same method as for a shoulder cut (for the square shouldered pommel). For a curved pommel, make two 90-degree lines—one for the ending point (meets the rounded area of your project) and one for the starting point of the pommel. I usually go ahead and create a square pommel at the end point. Then in a series of light cuts, add a curving motion to create the curved surface until you reach the line that marks the starting point of the pommel. If a relatively friendly wood, I lead with the long point through the entirety of the cut. If a difficult wood (usually very soft or easily torn on the end grain), I start with the long point in the wood, then raise the handle with my back hand to allow cutting in the area just above the long point.

ROLLING: using the skew to produce a convex shape, such as a bead. For small beads (under 3/8” wide or less) I often use the long point. For most beads and other convex shapes of a larger size I make the cut with the short point down. You may cut with the short point in the wood (to assist with keeping the tool against the side of the bead and with a bevel rubbing) or with the area above the short point but not above the center of the tool’s long cutting edge. Problems: skating (creating slashes in the bead), dig ins (getting the trailing edge/point pulled into the wood), shapes that are not rounded—but were intended to be convex.

COVING: using the skew to produce a concave shape. Usually done with the short point down, moving the tool with a scooping action. Here the curved edged skew certainly performs better. Problems: skating and failure to produce a curved surface in the cove.

ROUGH-GRAIN: using the skew as the final tool to work an area of twisted grain, severe chip-out or even a knot. First the area is lightly cut with a roughing gouge, cutting edge at a 90 angle to the lathe’s axis, with bevel support. Make the cuts across the difficult area lighter and lighter until almost dust like in their action. Next, be sure the tool rest is almost touching the wood, cutting edge of the skew is held parallel to the lathe’s axis, tool handle is horizontal, edge is presented in a scrapping approach with no bevel support. Make very light passes across the difficult area, completing with only the lightest of cuts.

END-GRAIN SCRAPE: using the skew for scraping directly across end –grain as found on the rims or bases of such projects as lidded boxes, goblets, toothpick holders, etc. Get the tool extremely sharp by honing, place the tool rest as close to the work as possible, present the tool facing the end-grain area, the tool handle should be horizontal (to present the edge in a scraping approach with no bevel support) and lightly scrape across the area. You should be getting tiny ribbons rising from the edge—if not, you may be tearing the grain.

SHARPENING OF THE LACER SKEWS

First let me describe the shape of the cutting edge. About one-fourth to one-third of the edge from the long point is a straight line—and 90 degrees to the long point edge. The balance of the edge is a curved shaped. Two other aspects of the edge are critical: try to maintain an angle of approximately 70 degrees from point to point, and grind the bevel length to approximately one-and-one half times the thickness of the steel.

Once these shapes and dimensions have been achieved, actual sharpening of the edge is next. Set the tool rest of a dry wheel grinder to the preferred bevel angle (achieved by grinding the length of the bevel to the one-and one half times formula). Start with the straight part of the edge held horizontally (or parallel to the axis of the grinder) and grind that region. Next, with a pivoting motion, grind the curved section when it is moved into a horizontal position on the wheel. I try to maintain the same position on the tool rest and simply pivot or rotate the tool from a single point. Grind until sparks just appear over the top edge of the tool. Turn the tool over and grind the other side in the same fashion. The objective is to grind a slight hollow-ground edge with a single facet. Work slowly and keep the skew flat on the tool rest of the grinder.

Next, I hone four faces of the skew. This is best done with a diamond honing stone in a “fine grit” of 500 or 600. Since there is now a hollow-ground edge, simply touch the stone at the back of the bevel, close the angle towards the cutting edge until you have a two-point contact at the back of the bevel and just below the cutting edge. Work the honing stone along both of the long cutting edges in this manner—normally with a “back and forth” motion.

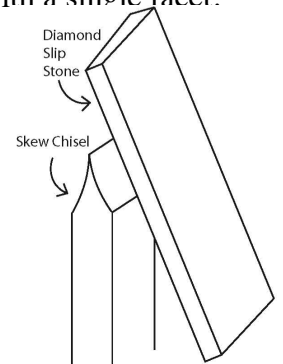

Then place the stone on the long flat edge behind the long point of the skew. Hone this area with the same back and forth motion, being sure to keep the stone flat on this surface. Finally, hone the area behind the short point in a similar fashion—even though that section has been rounded all the way to the ferrule, you can still refine the short point by keeping the hone flat on the edge behind the short point.

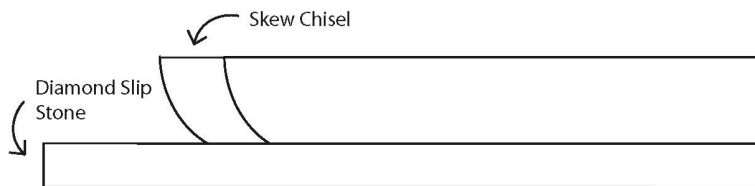

Honing is excellent following grinding to refine the edges, but also is used to keep the edges sharp while working. **Rule:** hone frequently and thereby avoid excessive trips to the grinder.

Thoughts on this grind:

I have tried a variety of grinds for the skew and prefer this style. I have found this grind—or similar grinds—being used by woodturners in North America over much of the last century. The advantages of it as I see it are several: the straight section is excellent for peeling cuts (much like a large parting tool), slicing rounded pommels with the long point down and as my scraping area; the straight section also serves as a warning to stay clear of when doing planing and rolling cuts (such as beads) with the short point leading the cut **AND** provides additional clearance of the trailing point in these cuts; the curved section works well for planing cuts in “chippy” woods; the curved edge wraps over a curve better than a straight section (as in convex shapes); the curved area can be used to scoop concave shapes.